

The versions – thread inserts for ultrasonic installation **SONICSERT®**



The advantages

- Suitable for thermoplastic parts
 - Especially designed for ultrasonic installation
 - Screw-locked and low-tension anchoring
 - High pull-out values
 - Type 0730 can be installed from both sides.
- Advantages for automatic feed, since no directional orientation is required.
Material: Cu Zn 38 Pb 2 (EU 2000/53 compliant)

Principle

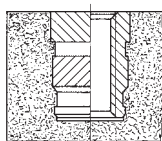

The **SONICSERT®** thread insert is installed with common ultrasonic welders. Upon welding, the plastic material is plasticised by ultrasonic vibrations and flows into the undercuts of the thread insert. Upon cooling, a low-stress interference is realised.

Technical data

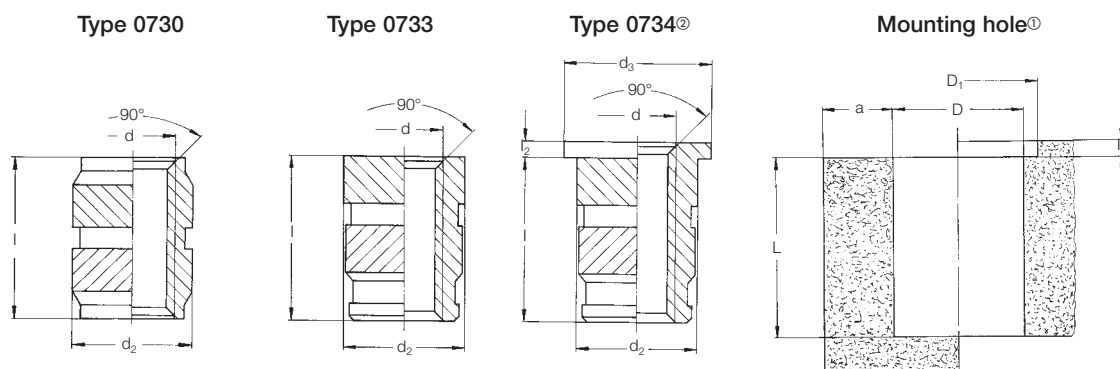

For installation tools and machines, see pages 16 – 18

d	Type 0730 Order No	Type 0733 Order No	Type 0734 [ⓐ] Order No	l	l ₂	d ₂	d ₃ [ⓑ]	D ^{+0.10}	D ₁	L _{min.}	a _{min.}
M 1.2 [ⓐ]	–	–	0734 112 0290	2.9	0.4	2.0	2.6	1.6	2.8	3.3	0.65
M 1.4 [ⓐ]	0730 114 0002	–	–	2.0	–	2.2	–	1.9	–	2.5	0.7
M 1.4 [ⓑ]	–	–	0734 114 0310	3.1	0.4	2.2	2.8	1.8	3	3.5	0.7
M 1.6 [ⓐ]	0730 116 0250	–	–	2.5	–	3.0	–	2.6	–	3.0	0.8
M 1.6 [ⓑ]	–	–	0734 116 0330	3.3	0.4	2.5	2.9	2.1	3.1	3.7	0.8
M 2	0730 102 0004	0733 102 0004	0734 102 0046	4.0	0.6	3.6	5.0	3.2	5.2	4.5	2.0
M 2.5	0730 125 0058	0733 125 0058	0734 125 0064	5.8	0.6	4.6	6.0	4.0	6.2	6.5	2.3
M 3	0730 103 0058	0733 103 0058	0734 103 0064	5.8	0.6	4.6	6.0	4.0	6.2	6.5	2.3
M 3.5	0730 135 0072	0733 135 0072	0734 135 0008	7.2	0.8	5.4	7.0	4.8	7.2	8.0	2.5
M 4	–	0733 104 0072	–	7.2	–	6.3	–	5.6	8.2	8.0	2.5
M 4	0730 104 0082	0733 104 0082	0734 104 0009	8.2	0.8	6.3	8.0	5.6	8.2	9.0	2.5
M 5	–	0733 105 0082	–	8.2	–	7.0	–	6.4	8.7	9.0	2.7
M 5	0730 105 0095	0733 105 0095	0734 105 0105	9.5	1.0	7.0	8.5	6.4	8.7	10.5	2.7
M 6	–	0733 106 0095	–	9.5	–	8.6	–	8.0	10.2	10.5	3.0
M 6	0730 106 0127	0733 106 0127	0734 106 0137	12.7	1.0	8.6	10.0	8.0	10.2	14.0	3.0
M 8	0730 108 0127	0733 108 0127	0734 108 0137	12.7	1.0	10.2	12.0	9.6	12.2	14.0	3.5

Metric ISO thread according to DIN 13-6H.
Technical modifications reserved.
All dimensions in mm.

[ⓐ] Guide values: depend on moulding material, may have to be changed after setting trials.
[ⓑ] The flange has a large contact surface and thus reduces surface pressure.
Minimum quantity on request.
[ⓒ] On request.

Other sizes, special designs and materials on request.

The versions – thread inserts for ultrasonic installation **SONICSERT®**

Technical data

Type 0743

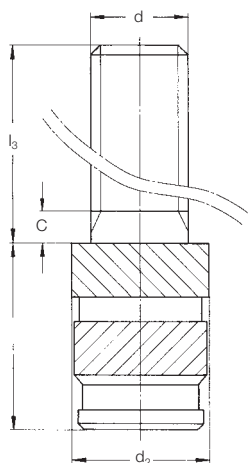

Type 0744®

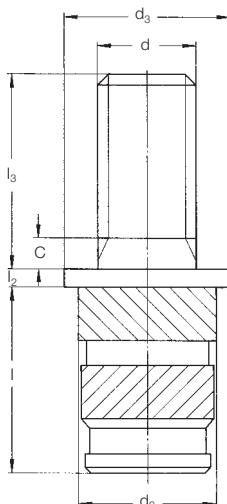

Mounting hole®

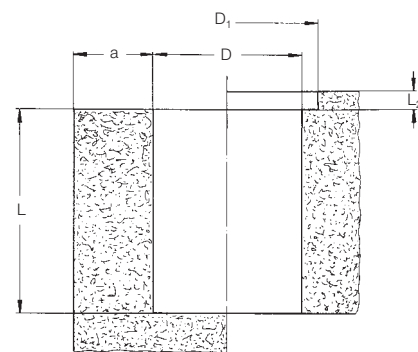

$C_{max} = 3P$

For installation tools and machines, see pages 16 – 18

d	Type 0743® Order No	Type 0744® Order No	l	l ₂ /L ₂	l ₃	d ₂	d ₃ ®	D ^{+0.10}	D ₁	L _{min}	a _{min}
M 2	0743 102 0005	0744 102 0005	4.0	0.6	5.0	3.8	5.0	3.2	5.2	4.5	2.0
	0743 102 0010	0744 102 0010	4.0	0.6	10.0	3.8	5.0	3.2	5.2	4.5	2.0
M 2.5	0743 125 0005	0744 125 0005	4.0	0.6	5.0	4.6	5.0	3.2	5.2	4.5	2.0
	0743 125 0010	0744 125 0010	5.8	0.6	10.0	4.6	6.0	4.0	6.2	6.5	2.3
M 3	0743 103 0005	0744 103 0005	5.8	0.6	5.0	4.6	6.0	4.0	6.2	6.5	2.3
	0743 103 0010	0744 103 0010	5.8	0.6	10.0	4.6	6.0	4.0	6.2	6.5	2.3
M 3.5	0743 135 0005	0744 135 0005	7.2	0.8	5.0	5.4	7.0	4.8	7.2	8.0	2.5
	0743 135 0010	0744 135 0010	7.2	0.8	10.0	5.4	7.0	4.8	7.2	8.0	2.5
M 4	0743 104 0005	0744 104 0005	8.2	0.8	5.0	6.3	8.0	5.6	8.2	9.0	2.5
	0743 104 0010	0744 104 0010	8.2	0.8	10.0	6.3	8.0	5.6	8.2	9.0	2.5
M 4	0743 104 0015	0744 104 0015	8.2	0.8	15.0	6.3	8.0	5.6	8.2	9.0	2.5
	0743 105 0010	0744 105 0010	9.5	1.0	10.0	7.0	8.5	6.4	8.7	10.5	2.7
M 5	0743 105 0015	0744 105 0015	9.5	1.0	15.0	7.0	8.5	6.4	8.7	10.5	2.7
	0743 105 0025	0744 105 0025	9.5	1.0	25.0	7.0	8.5	6.4	8.7	10.5	2.7
M 6	0743 106 0010	0744 106 0010	12.7	1.0	10.0	8.6	10.0	8.0	10.2	14.0	3.0
	0743 106 0015	0744 106 0015	12.7	1.0	15.0	8.6	10.0	8.0	10.2	14.0	3.0
M 6	0743 106 0025	0744 106 0025	12.7	1.0	25.0	8.6	10.0	8.0	10.2	14.0	3.0
	0743 108 0010	0744 108 0010	12.7	1.0	10.0	10.0	12.0	9.6	12.2	14.0	3.5
M 8	0743 108 0015	0744 108 0015	12.7	1.0	15.0	10.0	12.0	9.6	12.2	14.0	3.5
	0743 108 0025	0744 108 0025	12.7	1.0	25.0	10.0	12.0	9.6	12.2	14.0	3.5

Metric ISO thread according to DIN 13-6g.
Technical modifications reserved.
All dimensions in mm.

® Guide values: depend on moulding material, may have to be changed after setting trials.
® Minimum quantity on request, no stock type.
® The flange has a large contact surface and thus reduces surface pressure.

Other lengths, special designs and materials on request.

The versions – thread inserts for ultrasonic installation **SONICSERT®**

Technical data

Torque values SONICSERT® M 3 to M 8

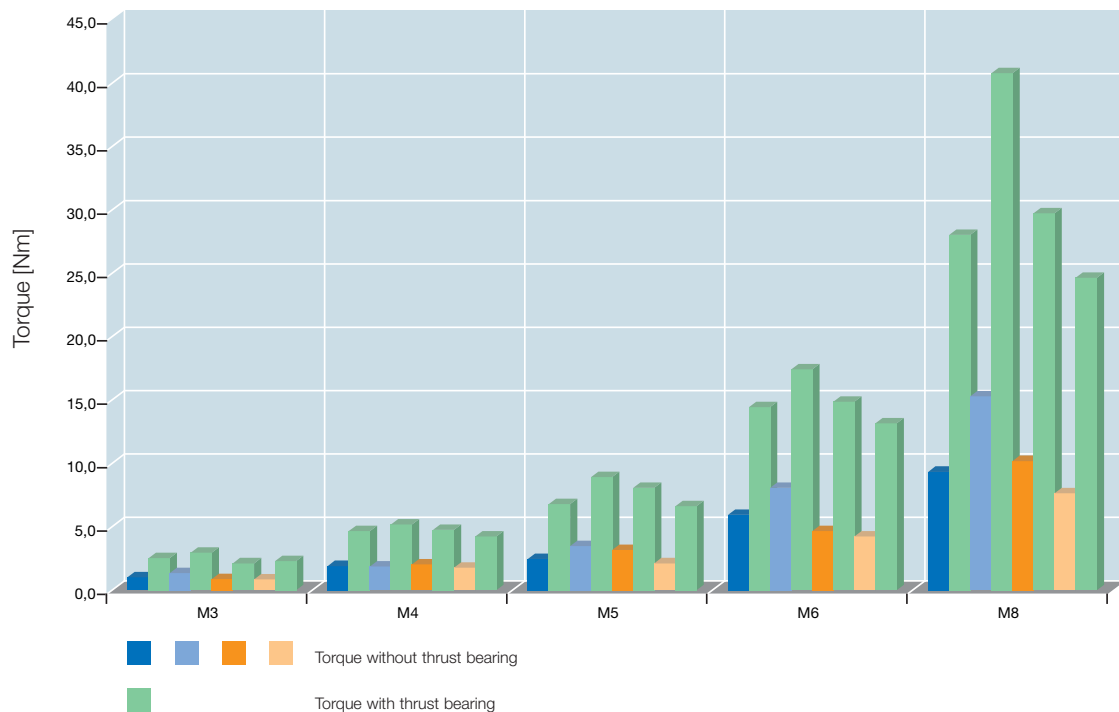

		M 3	M 4	M 5	M 6	M 8
■ ABS	MA [Nm]	1.00	1.90	2.50	6.00	9.40
■ ABS	MR [Nm]	2.60	4.70	6.80	14.50	28.10
■ PC	MA [Nm]	1.40	1.90	3.50	8.40	15.30
■ PC	MR [Nm]	3.00	5.20	8.90	17.40	40.80
■ PA	MA [Nm]	0.90	2.00	3.20	4.70	10.20
■ PA	MR [Nm]	2.10	4.80	8.10	14.90	29.80
■ PE/PP	MA [Nm]	0.90	1.80	2.10	4.30	7.70
■ PE/PP	MR [Nm]	2.30	4.30	6.60	13.20	24.70

All dimensions in mm.

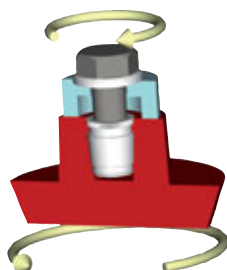

Torque without thrust bearing (MA[Nm])
(jack out)

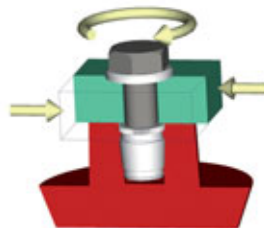

Torque with thrust bearing (MR[Nm])

Installation method thermal installation

Installation method self-tapping insertion

Installation method expansion anchoring

The versions – thread inserts for ultrasonic installation **SONICSERT®**

Technical data

Pull-out values SONICSERT® M 3 to M 8

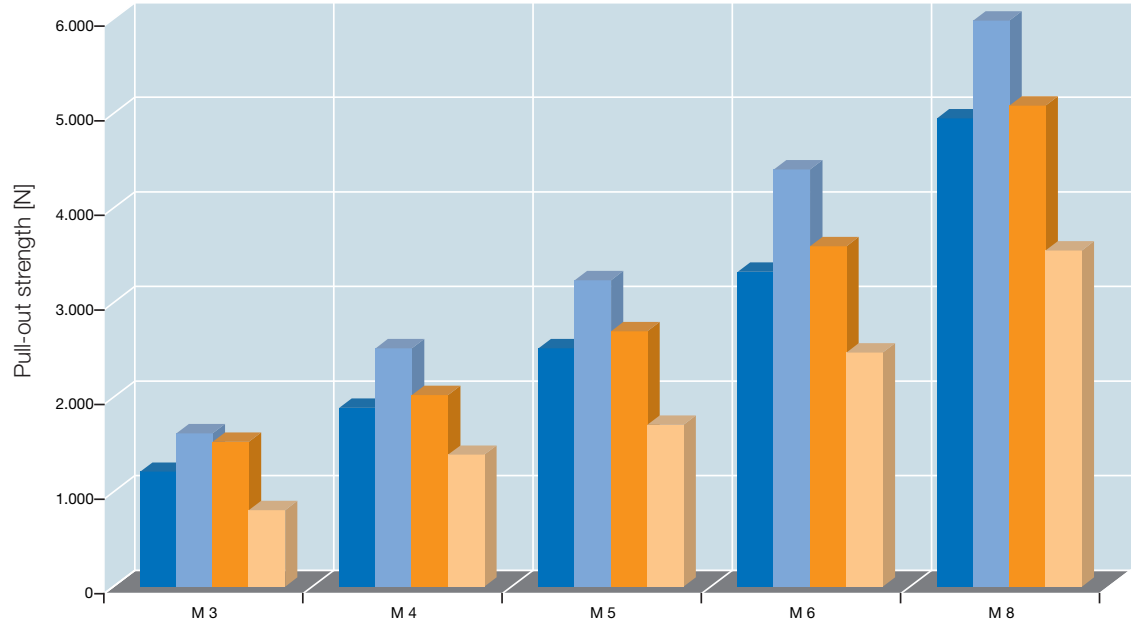

	M 3	M 4	M 5	M 6	M 8
■ ABS FA [N]	1,215	1,890	2,520	3,330	4,950
■ PC FA [N]	1,620	2,520	3,240	4,410	5,985
■ PA FA [N]	1,530	2,025	2,700	3,600	5,085
■ PE/PP FA [N]	810	1,395	1,710	2,475	3,555

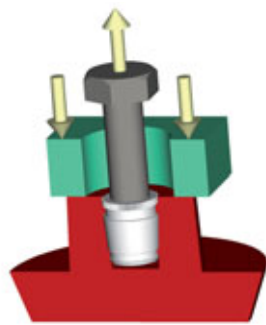

Pull-out strength (FA[N])

Technical notes

Indicated values are guide values. We recommend an installation test for the respective application. To be on the safe side, for fibre-reinforced plastics, the strengths of the non-reinforced material should be assumed. If you use brass thread inserts in plastics susceptible to stress cracks (e.g. polycarbonate), we recommend additional surface treatment of the thread inserts (nickel plating or surface coating as required). Strength values for other thread inserts on request.