



SNAPLOC®

Vibration and noise-decoupling
fastening systems

Kel
BULGARIA

BÖLLHOFF

SNAPLOC® Decoupling plug-in connections

Contents

	Page
The system	3
The function	3
The variants of the system	4
Installation tool for plate fastening	10
Your benefits	11
The main applications in the general industry	12
The main applications in the automotive industry	13
Technical information	14

SNAPLOC® Decoupling plug-in connections

The system

SNAPLOC® is a two-part system – ball stud and coupling – for fast installation. The coupling is inserted into the bottom of the respective cover in a specially designed mounting and held in a closed-form. The ball stud can be screwed into various mating components.

Simply push-fit to connect and pull apart to detach – SNAPLOC® provides optimal fastening.



The function

SNAPLOC® is based on the simple principle of a snap connection. A ball socket is formed within the coupling, in which the ball stud can snap into as a counter-piece.

The special features of SNAPLOC®: the connection compensates tolerances and isolates vibration and noise.



Detached connector



Attached connector

Here you can see a cross section of the coupling.

SNAPLOC® – The variants of the system

Ball studs

SNAPLOC® ball studs are available in six basic designs. They may be distinguished in the form of their fastening.

- Ball studs with external thread
- Ball studs with internal thread
- Ball studs with K' in K' (plastic in plastic) thread
- Ball studs in clip form
- Ball studs for injection moulding
- Ball studs for insertion

Four product variations are currently available which are defined by the characteristic of the ball head diameter (available are ball head diameters 7, 8, 10 and 15 mm).

The following parameters are variable – shaft length, thread diameter and thread length, material, colour, material of the blank and various drives, whereby two drives may also be realised per ball stud.

The various ball studs may be combined, in all ways, with the various coupling designs within one ball diameter.

Ball studs in metal/plastic combination

SNAPLOC® ball studs with external thread

The ball studs with metallic external threads are available with metric threads and in plastic self-tapping threads. Please contact us for further thread forms.

For the corresponding dimensions, please refer to pages 14 – 17.



SNAPLOC® ball studs with internal thread

The ball studs with metallic internal threads are primarily available with metric threads. Please contact us for further thread forms.

The corresponding dimensions may also be seen on the pages 18 – 19.



SNAPLOC® – The variants of the system



SNAPLOC® K' in K' – securely screwed into plastic

Due to special developed thread profiles, SNAPLOC® with K' in K' function enables a solution for self-tapping screw connections.

The patented thread geometry of the K' in K' principle is very important. The K' in K' thread forms or cuts into a cylindrical drill-hole a holding thread.

Due to the special thread form of the K' in K' thread, the screw is locked against loosening. In combination with the receiving component, a self-locking device is realised.

The K' in K' principle can be identified by the torque: To unscrew the thread, a higher torque is necessary than during installation.



SNAPLOC® ball studs in clip form

Due to the special geometry of the parts, these ball studs may be fastened by simply being clipped in an opening. A fastening solution which is highly suitable for applications in which a thread or bolt cannot be inserted into the part. For the corresponding opening geometries and plate thicknesses, please refer to the technical information on the pages 20 – 21.

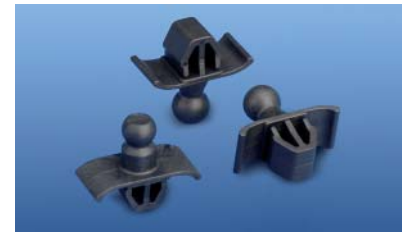

SNAPLOC® ball studs for injection moulding

For a secure system function, the adjustment between ball stud and coupling is decisive.

In order to produce economically, we offer ball studs suitable for the insertion into injection moulding tools and for the process of in-moulding. Hereby, the quality is assured.

SNAPLOC® ball studs for insertion

Compared to clipping, this version is inserted sideways by an open geometry into the component.

SNAPLOC® ball studs material

The ball studs are produced of high quality plastics, such as PA6 PA66 and PPA with 30 and 50 % glass fiber. The forces to be transmitted in the connection are restricted by the couplings. Furthermore, a ball stud made of plastics offers the advantages of thermal and electrical insulation.

SNAPLOC® – The variants of the system

Coupling

SNAPLOC® couplings are available in three basic designs. They vary in the type of fastening.

- Couplings for mounting dome with collar
- Couplings for mounting dome without collar
- Couplings for plate fastening

Four product variants are currently available which are defined through the characteristic of the ball head diameter of the ball stud. Available are ball head diameters 7, 8, 10 and 15 mm.

The following parameters are variable – external diameter, collared/collarless, collar depth, material, colour and other special designs.

The various couplings may be combined, in all ways, with the various ball stud designs within one ball diameter.

SNAPLOC® couplings for mounting dome

The couplings for mounting domes are designed so that they can be inserted automatically or manually into the corresponding locating holes, without requiring any additional tools. Thus, manual and automatic assembly is possible within a very short time.

The couplings are available with or without a collar.

Couplings with a collar are primarily designed for the fastening in mounting domes, but could be also fastened in plates. Due to the component geometry, an open bore is preferable.

For the corresponding dimensions, please refer to pages 24 – 27.

Example: view of installation and assembled condition

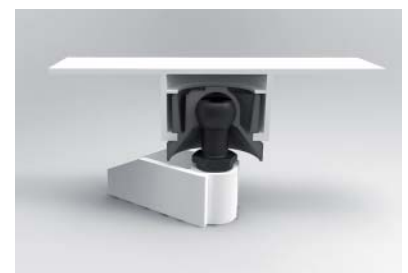

SNAPLOC® – The variants of the system

SNAPLOC® couplings for plate fastenings

Due to the geometry, these couplings may be mounted by simply being pushed into a specified bore or square opening. The corresponding bore diameters or opening geometries and plate thicknesses may be seen on pages 28 – 31.

The couplings can be assembled by pressing them easily into a mounting geometry. To simplify the assembly, we offer an installation tool. It may be found on page 10.

Example: view of assembled condition



SNAPLOC® angular coupling

Partially, the insertion direction of the connection and the fastening level are not arranged to each other in a right angle. Especially for the complex shaped parts with the free formed surfaces, it is not easy to generate these surfaces. To compensate angular differences, we offer the angular couplings. These couplings are mounted as well as those for plate fastening into the sheet and compensate additionally the angular difference. Thus, an assembly in insertion direction is again possible.

Available on request.



SNAPLOC® – The variants of the system

Couplings – material choice

Depending on the thermal and mechanical requirements, as well as fluid resistance, crosslinked elastomers/rubber or thermoplastic elastomers are used in injection moulding.

EPDM-X+PP or TPE-E

Thermoplastic processed elastomer

- Very good compression set
- Good resistance to chemicals
- Good resistance to mineral oils and greases

VMQ / LSR

Silicon on solid or liquid base

- Excellent compression behaviour
- High temperature resistance
- Low influence of temperature changes on mechanical characteristics

EPDM peroxide

Elastomer processed by vulcanising

- Very good compression set
- Good resistance to chemicals
- Good resistance to mineral oils and greases
- High temperature resistance

Comparison of TPE class properties

Properties	Cross-linked elastomers/rubber		Thermoplastic elastomers	
	EPDM Peroxid	VMQ + LSR	EPDM-X+PP	TPE-E
hardness (shore A/D)	30A - 90A	30A - 80A	35A - 50D	33D - 72D
temperature resistance °C	-40 to 150	-80 to 200	-40 to 120	-50 to 130
temperature behaviour	+	++	0	0
abrasion	+/0	-	-	+
compression set (at room temperature)	++	++	+	0
oil resistance	-	0	-	++
acid resistance	++	-	++	0
alkali resistance	++	-	++	0
ozone and weathering resistance	++	++	++	+

- ++ very good
- + good
- 0 average
- poor



SNAPLOC® – The variants of the system

Shore hardness – an overview

The shore hardness defines the material hardness of elastomers and rubber elastic polymers. Our offer includes different hardnesses of shore A and shore D (blue marking).

Hardness indicators	Very soft	Soft	Semi-soft	Semi-hard	Hard	Very hard
Shore OO	20 30 35 40 50 55 60	70	80	90	95 98	
Shore A		10 20 30	40	50	60 70 80	90 95 100
Shore D					22 25	35 45 55 65 75

Temperature behaviour of the SNAPLOC® couplings

Generally, a high correlation between the temperature and the forces to be transmitted exists. The used materials indicate overall a very different temperature behaviour (see illustration). EPDM-X+PP and EPDM peroxide show a modified disassembly force during miscellaneous temperatures; whereas silicon materials have a very constant behaviour.

Comparison temperature behaviour SNAPLOC® coupling by the example of d = 10 mm

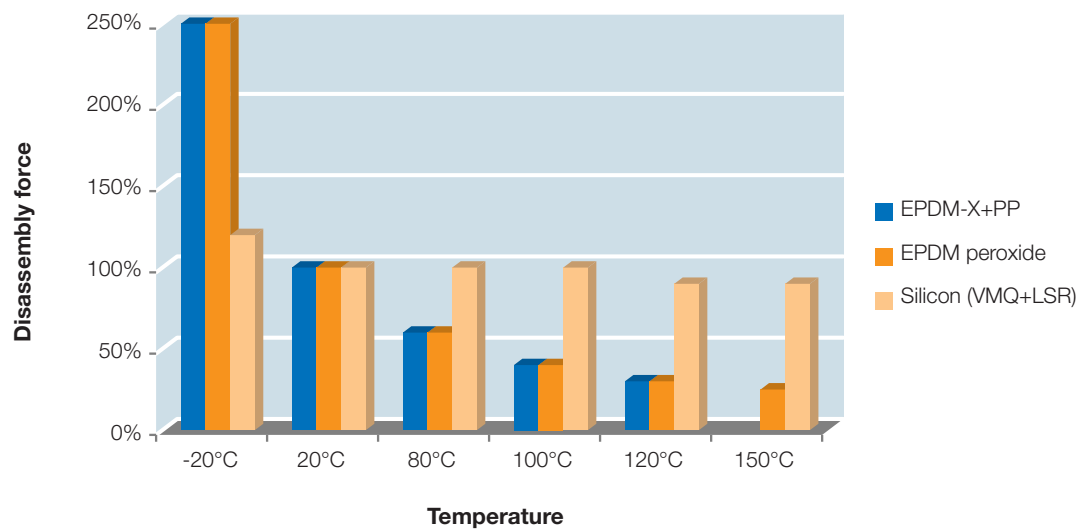

SNAPLOC® – Installation tool for plate fastening

During the pushing of a SNAPLOC® coupling into a drill-hole, the coupling is compressed. Therefore, the assembly can be varied at different shore hardnesses or geometries.

By using an installation tool, the coupling is stretched during the assembly, so that it is tapered in the outer diameter. This aids the assembly.



Pos.	Part number	Description
1	4099 999 9999	Handle
2	4099 999 9998	Large nozzle (standard)
7	4099 999 9997	Small nozzle for limited space
3	4099 999 9996	Shaft d = 15 mm
4	4099 999 9995	Shaft d = 10 mm
5	4099 999 9994	Shaft d = 8 mm
6	4099 999 9993	Shaft d = 7 mm

A complete installation tool consists of a handle, a nozzle and a shaft according to the required SNAPLOC® ball diameter.

SNAPLOC® – Decoupling plug-in connections

Your benefits

Fast and easy assembly

- Easy plug-on to assemble
- Unplug to disassemble

Decoupling fastening

- Decoupling of vibration and noises
- Tolerance compensation in the centre distances

Cost-effective

- Small number of parts
- Fast and easy assembly and disassembly

Easy integration

- Many variants thanks to diverse fastening options
- Integration of the parts in the component



SNAPLOC® – Decoupling plug-in connections**Fields of application in general industry**

SNAPLOC® can be implemented in different fields of application, e.g.:

Plant engineering

- Extraction channel at calender plant

**Store construction**

- Bar lighting

Filter technique

- Fastening filter frame

**Medical technology**

- Dialysis machine

Consumer electronics

- Decoration strip fastening for television sets
- Speaker fastening

**Mechanical engineering**

- Diesel particulate filter cover

Crane engineering

- Cabin coverings

**Fork lift trucks**

- Electronic assembly



SNAPLOC® – Decoupling plug-in connections

Possible and implemented main fields of application in automotive industry

Engine and aggregates

- NVH design hoods
- Engine cover
- Air filter fastening to suction pipe
- Fastening valve cover
- Fastening induction manifold
- Fastening engine control unit

Body (exterior)

- Trim panel bumper
- Fastening rear light

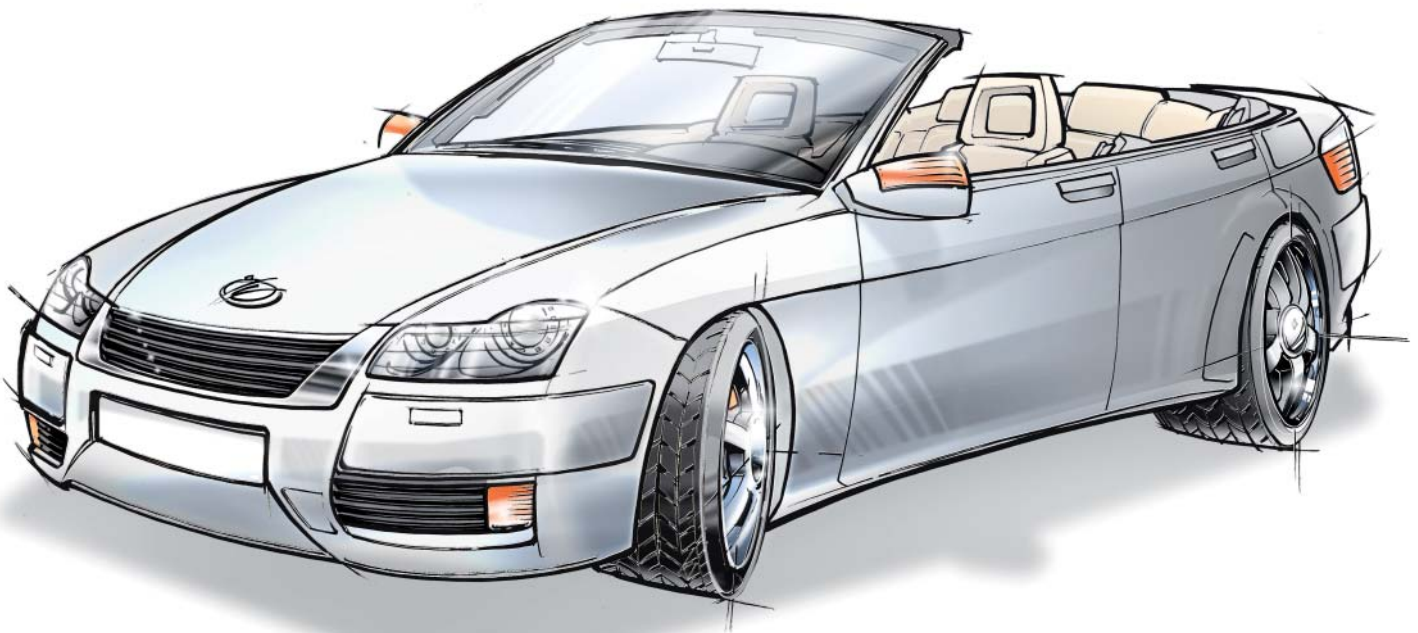

Interior

- Cockpit – instrument panel
- Seats – locker
- Cover/acoustics
- Rear shelf
- Fastening shelf to roof liner
- Climate control panel
- Loudspeaker

Body structure

- Rear end pre-fixation tool tray
- Fastening valve to strut
- A-pillar fastening
- Underbody fastening

SNAPLOC® Technical information
Studs with metrical external thread

Part number	Ball Ø in mm	Depth L1 (to ball center)	Type of thread	Thread dimensions	Thread length	Internal hex socket round ISO 10664
4039 015 0602	7	11,9	metrical	M 6	10	–
4030 007 0006	7	11,9	metrical	M 6	9	–
4039 007 0604	8	9,9	metrical	M 6	9	–
4039 008 0016	8	18	metrical	M 6	14	–
4039 008 0045	8	26,2	metrical	M 6	8	–
4039 008 0041	8	30,8	metrical	M 6	16	–
4039 008 0047	8	40	metrical	M 6	15	–
4031 100 3905	10	16	metrical	M 6	12	–
4039 007 0605	10	19,4	metrical	M 6	8	–
4030 010 0040	10	23	metrical	M 6	12	–
4039 006 0601	10	28	metrical	M 6	12	–
4039 010 0057	10	34	metrical	M 6	10	–
4030 010 0049	10	35,1	metrical	M 6	12	–
4039 017 0603	10	43,5	metrical	M 6	12	–
4039 001 0602	10	51	metrical	M 6	8	–
4030 015 0007	15	12	metrical	M 6	8	40
4039 005 0602	15	18	metrical	M 6	12	40
4030 015 0005	15	21	metrical	M 6	12	40
4039 015 0018	15	24	metrical	M 6	12	–
4034 150 3901	15	29	metrical	M 6	12	40
4039 005 0605	15	32	metrical	M 6	12	40
4039 003 0604	15	61	metrical	M 6	12	–

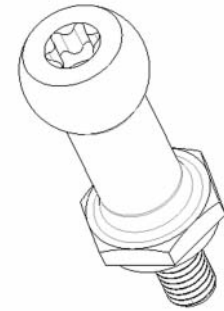
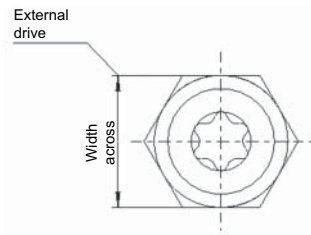
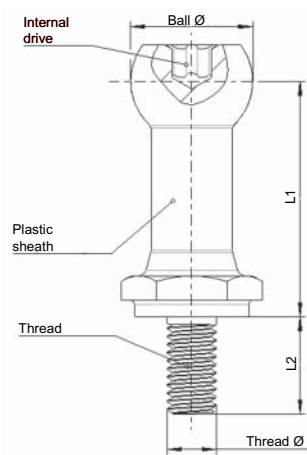

External drive	Material	Property class	Thread surface	Colour bolt
WS 10	PPA-GF50	solid plastics	Zn/Ni	black
WS 10	PPA-GF50	4.8	Zn/Ni	black
WS 10	PPA-GF50	4.8	Zn/Ni	black
WS 13	PPA-GF50	8.8	Zn/Ni	black
WS 17	PPA-GF50	4.8	Zn/Ni	black
WS 13	PPA-GF50	8.8	Zn/Ni	black
WS 10	PA66-GF50	8.8	Zn/Ni	black
WS 13	PPA-GF50	8.8	Zn/Ni	black
WS 13	PPA-GF50	4.8	Zn/Ni	black
WS 12	PA66-GF50	8.8	Zn	black
WS 13	PPA-GF50	8.8	Zn/Ni	black
WS 13	PPA-GF50	8.8	Zn/Ni	black
WS 12	PPA-GF50	8.8	Zn/Ni	black
WS 12	PPA-GF50	8.8	Zn/Ni	black
WS 13	PPA-GF50	8.8	Zn/Ni	black
WS 15	PPA-GF50	4.8	Zn/Ni	black
WS 15	PPA-GF50	4.8	Zn/Ni	black
WS 15	PPA-GF50	4.8	Zn/Ni	black
-	PPA-GF50	4.8	Zn/Ni	grey
WS 15	PPA-GF50	4.8	Zn/Ni	black
WS 15	PPA-GF50	4.8	Zn/Ni	black
WS 15	PA66-GF30	8.8	Zn	black

SNAPLOC® Technical information
Metal/plastic combination ball studs with self-tapping external thread



Part number	Ball Ø in mm	Depth L1 (to ball center)	Type of thread	Thread dimensions	Thread length	Internal hex socket round ISO 10664
4030 007 0027	7	11,9	self-tapping	6	13,7	–
4039 007 0032	7	22	self-tapping	ST 4,2	13	–
4030 080 3902	8	9,9	self-tapping	6	13,7	–
4039 008 0048	8	20	self-tapping	5	20	–
4030 010 0019	10	16	self-tapping	6	13,7	–
4030 010 0039	10	20,3	self-tapping	6	13,7	–
4032 150 3904	15	18	self-tapping	ST 6,3 DIN ISO 1478	30	40
4039 019 0601	15	61	self-tapping	6	13,7	–

Adjustable solid plastic ball studs

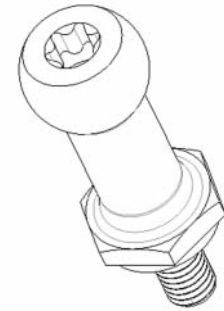
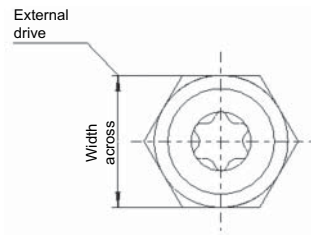
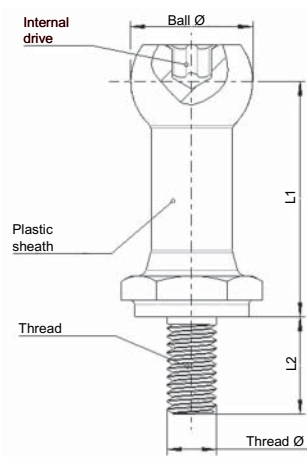
Part number	Ball Ø in mm	Depth L1 (to ball center)	Type of thread	Thread dimensions	Thread length	Internal hex socket round ISO 10664
4039 007 0601	10	12	metrical	M 6	21	25
4039 010 0031	10	13,1	metrical	M 6	14,4	30

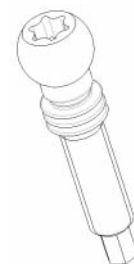
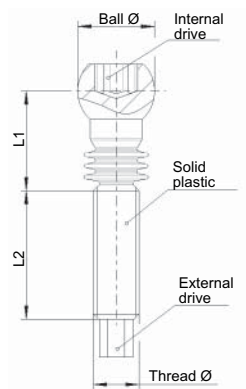

External drive	Material	Property class	Thread surface	Colour bolt
WS 10	PPA-GF50	–	ZNS 3	black
–	PA66-GF30	–	ZNS 3	black
WS 10	PPA-GF50	–	Zn	black
WS 13	PPA-GF50	–	Zn/Ni	black
WS 13	PPA-GF50	–	ZNS 3	black
WS 13	PPA-GF50	–	Zn/Ni	black
WS 15	PPA-GF50	–	ZNS 3	black
WS 15	PA66-GF30	–	Zn/Ni	black



External drive	Material	Property class	Thread surface	Colour bolt
–	PA66-GF30	solid plastics	Iges = 60	black
–	PA66/6GF30	solid plastics	Iges = 14,4	black

SNAPLOC® Technical information
**Metal/plastic combination ball studs
with internal thread**

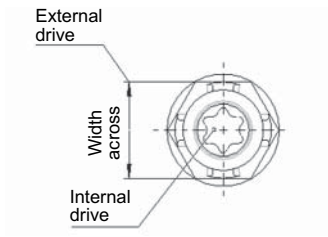
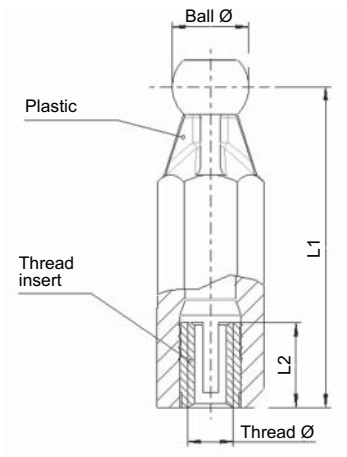

Part number	Ball Ø in mm	Depth L1 (to ball center)	Type of thread	Thread dimensions	Thread length	Internal hex socket round ISO 10664
4029 005 0601	8	18	metrical	M 6	10	–
4029 008 0002	8	25	metrical	M 6	17	–
4029 013 0504	10	37	metrical	M 5	10	–
4020 010 0009	10	42	metrical	M 6	10	–
4029 029 0601	10	54	metrical	M 6	11	–
4020 010 0006	10	62,6	metrical	M 6	10	–
4029 016 0604	10	78	metrical	M 6	11	–
4029 016 0605	10	113	metrical	M 6	11	–
4029 007 0601	15	12	metrical	M 6	8	–
4029 001 0601	15	97	metrical	M 6	11	40



	External drive	Material	Property class	Thread surface
	WS 13	PA6-GF50	plastics	black
	WS 10	PA6-GF50	plastics	black
	WS 12	PA66-GF30	CuZn38Pb2	black
	WS 12	PA66-GF30	CuZn38Pb2	black
	WS 13	PA66-GF30	CuZn38Pb2	natural-coloured
	WS 12	PA66-GF50	CuZn38Pb2	black
	WS 15	PPA-GF50	CuZn38Pb2	black
	WS 15	PPA-GF50	CuZn38Pb2	natural-coloured
	WS 15	PA66-GF30	plastics	black
	-	PA66-GF30	CuZn38Pb2	black

SNAPLOC® Technical information
Solid plastic ball studs with K' in K' thread

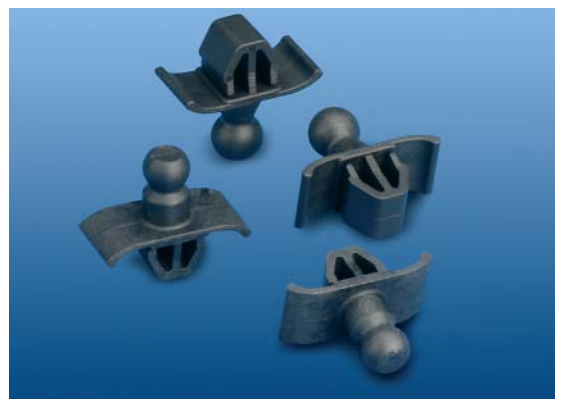
Part number	Ball Ø in mm	Depth L1 (to ball center)	Type of thread	Thread dimensions	Thread length	Internal hex socket round ISO 10664
4019 007 0601	7	11,7	K' in K'	Size 6	10	–
4010 081 3612	8	9,9	K' in K'	Size 6	12	–
4019 008 0009	8	21	K' in K'	Size 8	12	–
0419 008 0801	10	16	K' in K'	Size 8	15	–
0419 008 0801	15	14,5	K' in K'	Size 8	15	Form Z size 4*
4012 150 3815	15	18	K' in K'	Size 8	15	Form Z size 4*

Solid plastic-ball studs in clip form

Part number	Ball Ø in mm	Depth L1 (to ball center)	Type of thread	Thread dimensions	Thread length	Internal hex socket round ISO 10664
4009 018 1301	7	11	d = 10 mm	t = 2-3mm	–	–
4001 082 3084	8	10	8 x 10	t = 2+0,3mm	–	–

* Here cross recess as internal drive

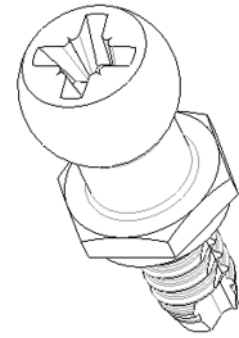
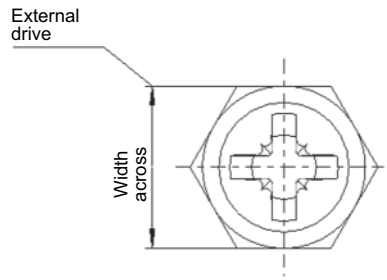
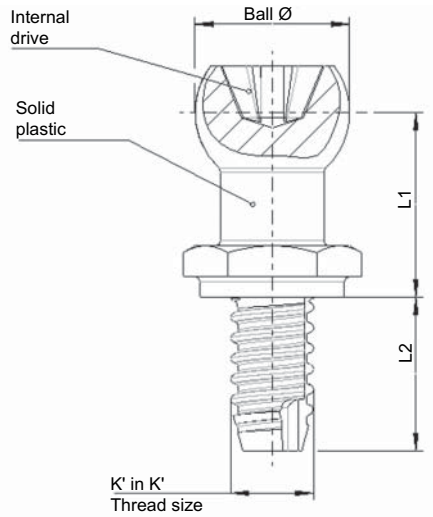

External drive	Material	Property class	Thread surface
WS 10	PPA-GF50	solid plastics	black
WS 8	PEI-GF30	solid plastics	black
WS 12	PPA-GF50	solid plastics	black
WS 13	PPA-GF50	solid plastics	black
WS 15	PPA-GF45	solid plastics	black
WS 15	PPA-GF50	solid plastics	black

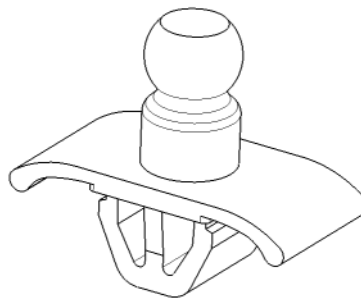
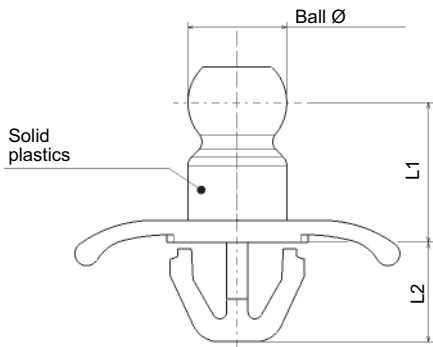

External drive	Material	Property class	Thread surface
-	PA6-GF50	solid plastics	black
-	PA6-GF50	solid plastics	black

SNAPLOC® Technical information
Solid plastic-ball studs for injection moulding

Part number	Ball Ø in mm	Depth L1 (to ball center)	Type of thread	Thread dimensions	Thread length	Internal hex socket round ISO 10664
0499 085 0003	7	7	–	plate d = 12	–	–
4099 007 0001	7	11,2	–	plate d = 12	–	–

Solid plastic-ball studs for insertion

Part number	Ball Ø in mm	Depth L1 (to ball center)	Type of thread	Thread dimensions	Thread length	Internal hex socket round ISO 10664
4009 007 0001	7	9,2	–	b = 5	–	–
40290 100 001	7	10	–	b = 4	–	–

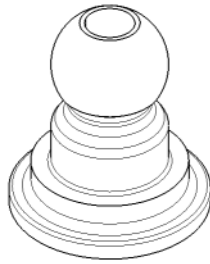
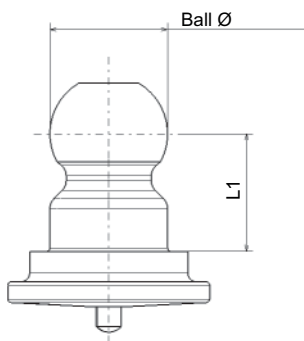

External drive	Material	Thread surface
–	PA66-GF30	black
–	PA6-F50	black

External drive	Material	Thread surface
–	PA66-GF30	black
–	PPA-GF50	black

SNAPLOC® Technical information
Couplings with collar for mounting dome

Part number	Design	Ball Ø D	Outer Ø d2	Mounting hole Ø d3	Collar Ø d4	Depth (to ball center L1)
4040 100 2324	collared	10	24	22	32	16
4040 100 3024	collared	10	24	22	32	16
4040 101 3024	collared	10	24	22	32	16
4040 010 0012	collared	10	26	22	32	16
4050 015 0040	collared	15	31,5	27	34	26
4040 150 3032	collared	15	32	28	36	19
4040 153 3032	collared	15	32	28	36	19

**Coupling with collar for mounting dome
High temperature applications**

Part number	Design	Ball Ø D	Outer Ø d2	Mounting hole Ø d3	Collar Ø d4	Depth (to ball center L1)
4040 010 0001	collared	10	24	22	32	16

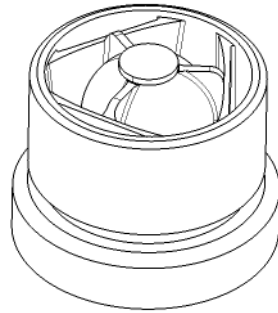
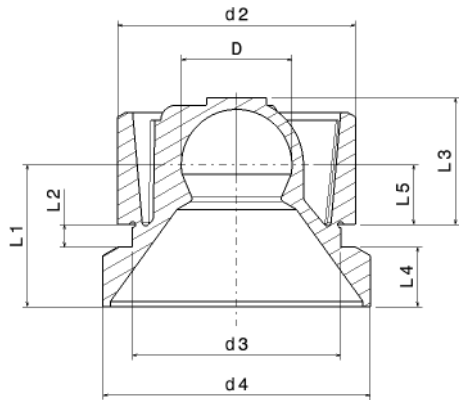

Wall thickness L2	Mounted depth L3	Collar depth L4	Depth L5	Material	Shore hardness	Thread surface
3	12	7	6	EPDM-X+PP	59 Shore A	black
3	12	7	6	EPDM-X+PP	78 Shore A	black
3	12	7	6	EPDM-X+PP	86 Shore A	black
3	12	7	6	EPDM-X+PP	78 Shore A	black
3-3,5	ca. 17,7	3,5	8	EPDM-X+PP	86 Shore A	black
3	15	8	8	EPDM-X+PP	78 Shore A	black
3	15	8	8	EPDM-X+PP	93 Shore A	black

Wall thickness L2	Mounted depth L3	Collar depth L4	Depth L5	Material	Shore hardness	Thread surface
3	12	7	6	EPDM peroxide	70 Shore A	black

SNAPLOC® Technical information
Coupling without collar for mounting dome

Part number	Design	Ball Ø D	Outer Ø d2	Mounting hole Ø d3	Collar Ø d4	Depth (to ball center L1)
4041 080 3018	collarless	8	18	14	–	7,9
4041 100 3024	collarless	10	24	22	–	9
4041 101 3024	collarless	10	24	22	–	9
4041 152 3032	collarless	15	32	28	–	11
4041 150 3032	collarless	15	32	28	–	11

**Couplings without collar for mounting dome
High temperature applications**

Part number	Design	Ball Ø D	Outer Ø d2	Mounting hole Ø d3	Collar Ø d4	Depth (to ball center L1)
4041 080 7318	collarless	8	18	14	–	7,9
4041 108 3024	collarless	10	24	22	–	9
4040 015 0010	collarless	15	40	36	–	21
4040 015 0011	collarless	10	32	28	–	10,3

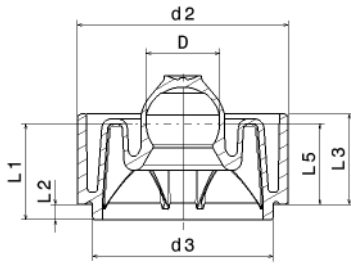

Wall thickness L2	Mounted depth L3	Collar depth L4	Depth L5	Material	Shore hardness	Thread surface
3	10	-	4,9	EPDM-X+PP	78 Shore A	black
3	12	-	6	EPDM-X+PP	78 Shore A	black
3	12	-	6	EPDM-X+PP	86 Shore A	black
3	15	-	8	EPDM-X+PP	59 Shore A	black
3	15	-	8	EPDM-X+PP	78 Shore A	black

Wall thickness L2	Mounted depth L3	Collar depth L4	Depth L5	Material	Shore hardness	Thread surface
3	10	-	4,9	TPE-E	38 Shore D	black
3	12	-	6	EPDM peroxide	70 Shore A	black
3	18	-	16	EPDM peroxide	70 Shore A	black
3	15	-	7,3	VMQ	60 Shore A	grey

SNAPLOC® Technical information
Couplings for plate fastening

Part number	Design	Ball Ø D	Outer Ø d2	Mounting hole Ø d3	Collar Ø d4	Depth (to ball center L1)
4070 070 4312	plate fastening	7	17	14	20	6,7
4070 070 3012	plate fastening	7	17	14	20	6,7
4070 070 1312	plate fastening	7	17	14	20	6,7
0499 085 0006	plate fastening	7	11	10	14	7
0499 085 0001	plate fastening	7	11	10	14	7
4062 070 0310	plate fastening	7	11	10	14	8,2
4050 007 0027	plate fastening	7	11	10	14	8,5
4050 007 0026	plate fastening	7	11	10	14	6,2
4060 070 4310	plate fastening	7	11,5	10	14	8,7
4050 007 0038	plate fastening	7	11	10	14	6,2
4059 011 0801	plate fastening	8	22	18	25	10,9
4050 080 3018	plate fastening	8	22	18	25	7,9
4050 010 0028	plate fastening	10	21,5	18	25	10,9
4059 010 0029	plate fastening	10	21,5	18	25	10,9
4050 010 0007	plate fastening	10	21,5	16 – 18,5	25	10,9
4050 010 0008	plate fastening	10	25,5	22	32	16
4050 015 0009	plate fastening	15	31,5	27	34	16
4250 015 0001	plate fastening	15	37	33	38	13,5

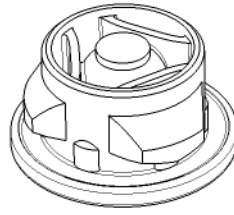
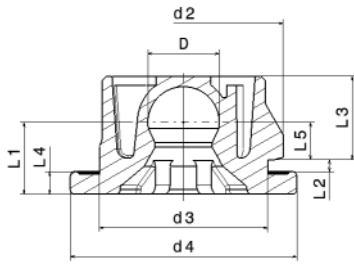

	Wall thickness L2	Mounted depth L3	Collar depth L4	Depth L5	Material	Shore hardness	Thread surface
	0,8 – 2	–	2,2	4,5 – L2	EPDM-X+PP	69 Shore A	black
	0,8 – 2	–	2,2	4,5 – L2	EPDM-X+PP	78 Shore A	black
	0,8 – 2	–	2,2	4,5 – L2	EPDM-X+PP	86 Shore A	black
	0,9	–	1,5	4,6	EPDM-X+PP	78 Shore A	black
	0,9	–	2	4,1	EPDM-X+PP	93 Shore A	black
	1,5	–	2	4,7	EPDM-X+PP	78 Shore A	black
	1,5	–	2,6	4,6	EPDM-X+PP	86 Shore A	black
	2	–	2	4,2	EPDM-X+PP	38 Shore A	black
	2	–	2,5	4,2	EPDM-X+PP	69 Shore A	black
	2	–	2	4,2	EPDM-X+PP	93 Shore A	black
	2	–	5,5	3,4	EPDM-X+PP	69 Shore A	black
	2	–	2,5	3,4	EPDM-X+PP	78 Shore A	black
	2 – 3	–	3,5	6	EPDM-X+PP	69 Shore A	black
	2 – 3	–	3,5	6	EPDM-X+PP	78 Shore A	black
	2 – 3	–	3,5	6	EPDM-X+PP	86 Shore A	black
	3	–	7	6	EPDM-X+PP	78 Shore A	black
	3 – 3,5	–	5,2	8	EPDM-X+PP	78 Shore A	black
	2 – 2,5	–	3,5	8	EPDM-X+PP	69 Shore A	black

SNAPLOC® Technical information
Couplings for plate fastening
High temperature applications

Part number	Design	Ball Ø D	Outer Ø d2	Mounting hole Ø d3	Collar Ø d4	Depth (to ball center L1)
4269 023 0701	plate fastening	7	12,4	10	16	8
4059 007 0010	plate fastening	7	16,5	14	20	8
4059 008 0006	plate fastening	8	18,5	16	26	10,5
4050 010 0012	plate fastening	10	22,5	18	25	11

Couplings SNAPLOC® HT-3D plate fastening
High temperature applications

Part number	Design	Ball Ø D	Outer Ø d2	Mounting hole Ø d3	Collar Ø d4	Depth (to ball center L1)
4059 007 0020	plate fastening	7	16	14	18,8	7,2
4252 070 7314	plate fastening	7	17,5	14	25	8
4250 080 7318	plate fastening	7	21	18	25	7,9
4250 081 0318	plate fastening	8	21	18	25	7,9
4250 150 7334	plate fastening	15	37	33	38	13,5

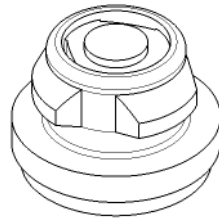
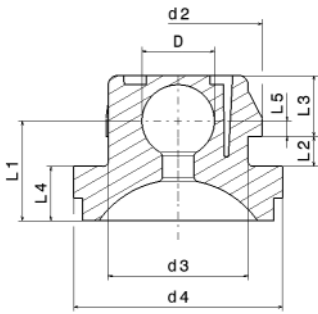

Wall thickness L2	Mounted depth L3	Collar depth L4	Depth L5	Material	Shore hardness	Thread surface
1 – 2	–	1,5	5,2	TPE-E	33 Shore D	black
2 – 2,5	–	3,5	2	ECO according to TL 52052	60 Shore A	black
2 – 2,5	–	3,5	4,75	VMQ	50 Shore A	black
2,5 – 3,2	–	3,5	6	VMQ	70 Shore A	grey

Wall thickness L2	Mounted depth L3	Collar depth L4	Depth L5	Material	Shore hardness	Thread surface
1	–	1,5	4,7	TPE-E	33 Shore D	black
1	–	2,5	4,5	TPE-E	33 Shore D	black
2 – 2,5	–	2,2	3,4	TPE-E	33 Shore D	black
2 – 2,5	–	2,2	3,4	TPE-E	40 Shore D	black
2 – 2,5	–	3,5	8	TPE-E	33 Shore D	black

Böllhoff International with companies in:

Argentina
Austria
Brazil
Canada
China
Czech Republic
France
Germany
Hungary
India
Italy
Japan
Mexico
Poland
Romania
Russia
Slovakia
Spain
Turkey
United Kingdom
USA

Apart from these 21 countries, Böllhoff supports its international customers in other important industrial markets in close partnership with agents and dealers.



Made of paper certified with the Ecolab of the European Community (Reg No. FR/11/003).
Printed by FSC®-certified company GFA-COC-001790.

Subject to technical change.
Reprinting, even in extract form, only permitted with express consent.
Observe protective note according to DIN 34.

KEL Bulgaria Ltd.
Please find your local contact on www.kelbulgaria.com
or contact us under info@kelbulgaria.com
Telephone: +359 877008832
Fax: +359 24922552

