

## DSE Series pneumatic tools

### Pistol

0,4 to 12 NM

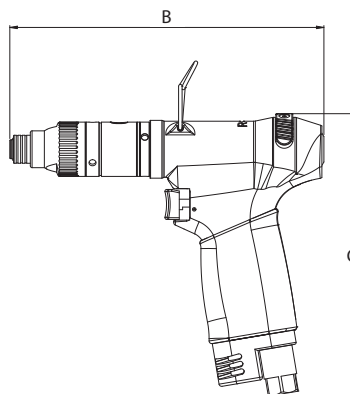
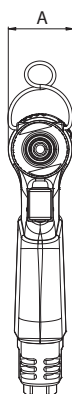

### DSE L Pistol

Model	Torque (Nm)	Speed (rpm)	Weight (Kg)	A	B	C	Code
<b>Trigger models</b>							
DSEL PA35G1400	0,4 - 3,5	1400	0,72	37,3	179,3	161,2	4-1588808
DSEL PA45G950	0,4 - 4,5	950	0,72	37,3	179,3	161,2	4-1588807
DSEL PA50G650	0,4 - 5	650	0,72	37,3	179,3	161,2	4-1588806

• Noise level 73 dBA • Air consumption 510 L/min • Vibration level <2,5 m/s<sup>2</sup> • Air hose inner diameter : 6 mm • Air fitting 1/4" gaz  
 Standard equipment delivered with the tool : Suspension ring, cover ring for reaction arm, torque setting screwdriver.

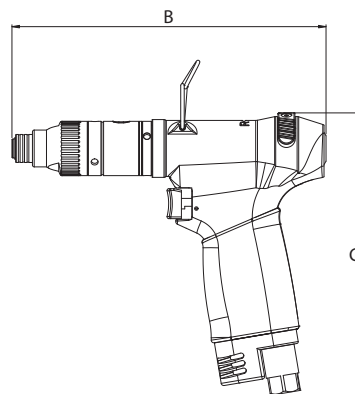

### DSE I Pistol

Model	Torque (Nm)	Speed (rpm)	Weight (Kg)	A	B	C	Code
<b>Trigger models</b>							
DSEI PA40G2000	0,4 - 4	2000	1,00	43,8	196	165,3	4-1588824
DSEI PA50G1300	0,4 - 5	1300	1,00	43,8	196	165,3	4-1588823
DSEI PA80G1000	3,5 - 8	1000	1,10	43,8	215,8	165,3	4-1588822
DSEI PA95G800	3,5 - 9,5	800	1,10	43,8	215,8	165,3	4-1588821
DSEI PA120G400	3,5 - 12	400	1,10	43,8	215,8	165,3	4-1588819

• Noise level 73 dBA • Air consumption 760 L/min • Vibration level <2,5 m/s<sup>2</sup> • Air hose inner diameter : 8 mm • Air fitting 1/4" gaz  
 Standard equipment delivered with the tool : Suspension ring, cover ring for reaction arm, torque setting screwdriver.